

# Internal Gear Driven Pump IPZ 1 - HR 3 Standard with 0,18 ccm/RPM

Default Design (Clockwise Shaft Rotation Viewed)

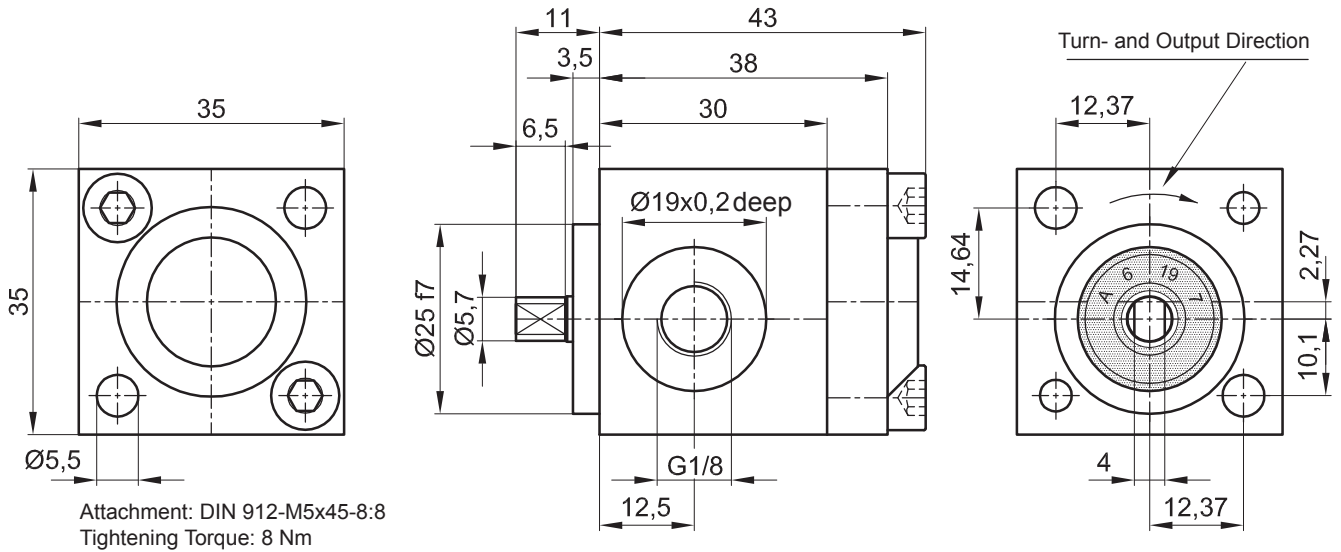

Attachment: DIN 912-M5x45-8:8  
Tightening Torque: 8 Nm

Symbol:



The technical data are based on a viscosity of 46 sq mm/s

ccm/ rpm	Press./bar max.		RPM max.		RPM min.	Mass	Order No.
	P1	P max	Press. P1	Depress.	Press. P1		
0,18	80	120	4000	5000	1000	300 g	10003-142

P1 = Working Pressure max. P max. = Pressure Peak

Working Pressure / bar							
Capacity at 1.500 RPM (l/min)							
Power Consumpt./W at 1.500 RPM							
bar	10	20	40	60	80	100	120
l/min	0,26	0,25	0,24	0,22	0,20	0,18	0,15
Watt	9	18	36	54	72	90	108

Working Pressure / bar							
Capacity at 3.000 RPM (l/min)							
Power Consumpt./W at 3.000 RPM							
bar	10	20	40	60	80	100	120
l/min	0,53	0,52	0,51	0,49	0,47	0,45	0,42
Watt	18	36	72	108	144	180	216

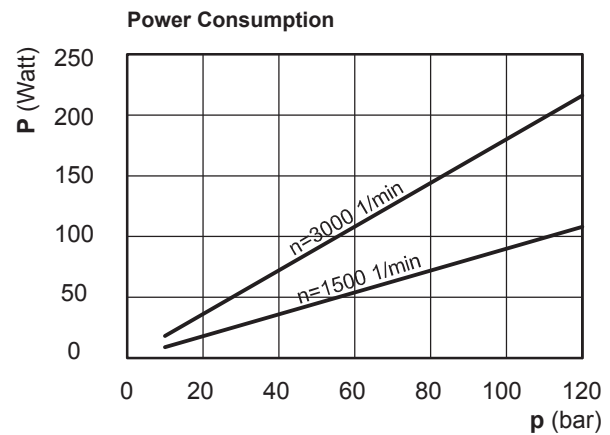
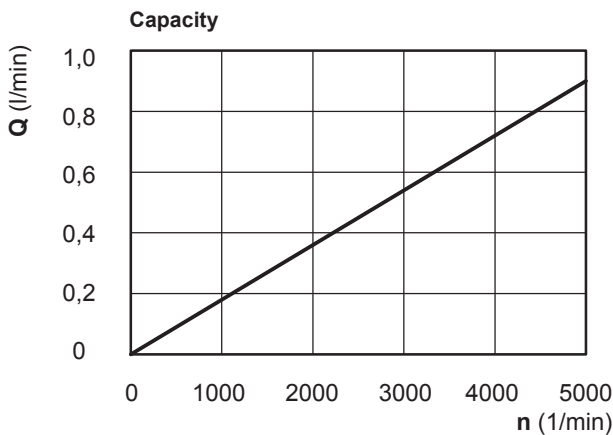

Please specify Pressure, RPM, Temperature, Gain and the Duty Cycle by ordering!



**Jung-Fluidtechnik GmbH**  
Mohrenstrasse 7  
D-76275 Ettlingen

**Phone** +49 (0) 7243-14648  
**Fax:** +49 (0) 7243-17996  
**E-Mail:** info@jung-fluid.de

Data Sheet

**IPZ 1 - HR 3**  
subject to modifications